

# JET

**JDP-15**

**Drill Press**

**10000370M  
230/50/1**

**10000370T  
400/50/3**

## **PARTS LIST**

**Walter Meier (TOOL) AG**  
Tämperlistr. 5  
CH-8117 Fällanden  
Switzerland  
Phone +41 44 806 47 48  
Fax +41 44 806 47 58  
[jetinfo.eu@waltermeier.com](mailto:jetinfo.eu@waltermeier.com)  
[www.jettools.com](http://www.jettools.com)



P-10000370M

2010-08

# Parts Breakdown for JDP-15 Drill Press

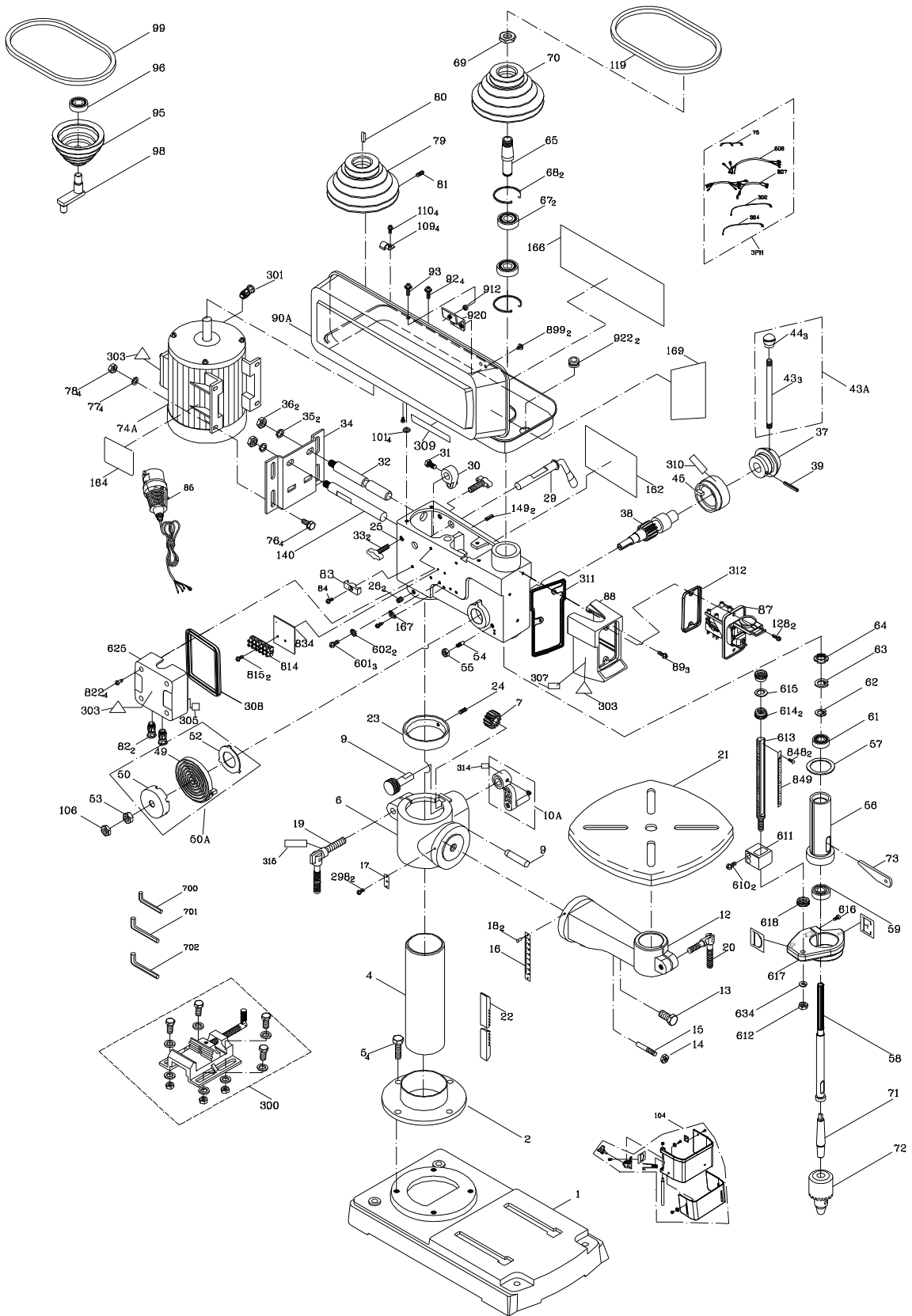

### Parts List for JDP-15 Drill Press

Index No.	Part No.	Description	Size	Qty.
1	10600128	Base		1
2	10400201	Column Holder		1
4	10600404	Body Column		1
5	2601BBDA72	Hex Head Bolt	M10x40mm	4
6	10600604	Table Bracket		1
7	10600702	Gear		1
8	10600802	Gear Shaft		1
9	10600902	Worm		1
10A	10601009A1	Crank Handle Assy		1
12	10601201	Table Bracket		1
13	2601QBDK85	Hex Head Bolt	5/8"x1"	1
14	2603BBLA38	Set Screw	M6x10mm	1
15	10901402	Pin		1
16	10601601	Tilting Scale		1
17	10801701	Centering Scale		1
18	2658MZDU36	Drive Screw		2
19	10601901	Column Lock Handle	M12x35mm	1
20	10602001	Table Lock Handle	M10x25mm	1
21	10602138	Table		1
22	10602204	Rack		1
23	10602304	Rack Ring		1
24	2603BBLA37	Set Screw	M6x8mm	1
25	10062LAH	Head		1
26	2603BBLA66	Set Screw	M10x12mm	2
29	10602901	Handle Shifter		1
30	10603002	Motor Bar Shifter		1
31	2601BZDAA9	Hex Head Bolt	M8x16mm	1
32	10603206	Motor Rod		1
33	10603301	Shifter Bolt	M10x33mm	2
34	10703414	Motor Base		1
35	2502NBC412	Spring Washer	1/2"	2
36	2701FBD112	Hex Nut	M12	2
37	10603704	Hub		1
38	10603807	Feed Shaft		1
39	2536MBE611	Spring pin	ø5x16mm	1
43A	10604303A1	Handle Assy		1
43	10604303	Handle Bar		3
44	10604403	Gripe		3
45	10604505	Scale Ring		1
49	10604902	Coil Spring		1
50A	10605002A3	Spring Cap Assy		1
50	10605002	Spring Cap		1
52	10605202	Spring Retainer		1
53	2701QZD611	Nut	1/2"-20	1
54	10605403	Quill Set Screw	M10x28mm	1
55	2701FBD110	Nut	M10	1
56	10605608	Quill		1
57	10605702	Rubber Washer		1
58	10605822	Spindle		1
59	2001ZZ6204	Ball Bearing	6204ZZ	1
61	2001ZZ6203	Ball Bearing	6203ZZ	1
62	10606201	Washer		1

Index No	Part No	Description	Size	Qty.
63	10606301	Lock Nut		1
64	10606401	Spindle Nut (L.H Threads)		1
65	10606505	Driving Sleeve		1
66	2001ZZ6204	Ball Bearing	6204ZZ	2
67	10606703	Collar		1
68	10606801	Retaining Ring		2
69	10606904	Pulley Set Nut		1
70	10607029	Spindle Pulley		1
71	21015M2B16	Drilling Arbor		1
72	2135ATQ915	Keyless Chuck	B-16	1
73	10607303	Wedge Shifter		1
74A	80062ZMR	Motor (230V, 50Hz, 1ph)		1
	8D66D12033A1	Motor (400V, 50Hz, 3ph)		1
75	280630RF	Motor Wire (1ph)		1
76	2615BBDD28	Hex Head Bolt	M8x25mm	4
77	2501MBDN08	Flat Washer	M8	4
78	2701FBD113	Nut	M8	4
79	10407994	Motor Pulley		1
80	2571MNC307	Key	5mmx5mmx20mm	1
81	2603BBLA36	Set Screw	M6x6mm	1
82	2801ANHJ37	Strain Relief		2
83	10808301	Cord Clamp		1
84	2668BBDA39	Cr. Re. Pan Hd. Screw		1
85	2807UK026M	Power Cable (1ph)		1
	2807WU0207	Power Cable (3ph)		1
87	28992Q5N	Switch (230V, 1ph)		1
	28992Q5M	Switch (400V, 3ph)		1
88	100630GU	Switch Box		1
89	2668BBDA24	Pan Head Screw	M5x12mm	3
90A	10062ZRN	Pulley Cover Assy		1
92	2641BBDA39	Pan Head Screw	M6x12mm	4
93	2620BBDB11	Pan Head Screw	M5x25mm	1
95	10409513	Center Pulley		1
96	2001ZZ6202	Ball Bearing	6202ZZ	1
98	10609802	Center Pulley Shaft		1
99	2572ARM260	V-Belt	M-26	1
101	2501NNVN11	Flat Washer	1/4"	4
104	10042RAJ	TRANSPARENT GUARD ASS'Y		1
106	2701QZD611	Nut	1/2"	1
109	10208302	Clamp-Cord		4
110	2668BBDA24	Pan Head Screw	M5x8mm	4
119	2572ARM240	V-Belt	M-24	1
128	26612ZME	Tapping Screw	M6 x35mm	2
140	10614001	Motor Rod		1
149	2536MBE616	Spring Pin	ø6x25	2
162	10062343	I.D Label		1
164	10062344	Motor Label		1
166	10316605	Speed Diagram		1
167	10216714	Earth Label		1
169	11316904	JET Logo		1
298	2668BBDA22	Pan Head Screw	M5x6mm	2
601	2668BZDA23	Pan Head Screw	M5x8mm	3
602	2504MZC005	Tooth Lock Washer		2
610	2668BBDB44	Pan Head Screw	M6x35mm	2
611	10661102	Seat		1
612	2701FBD109	Nut	M10	1
613	10661301	Scale Bolt		1
614	13005701	Nut	M16	2

Index No	Part No	Description	Size	Qty.
615	13005601	Washer		1
616	2602BBLA58	Hex Socket Cap Screw	M8x35mm	1
617	10062Z5X	Set Ring		1
618	10661801	Circular Nut		1
625	10062ZEN	Wire Box		1
634	2502ABC410	Spring Washer	M10	1
700	2138MBL703	Angle Wrench		1
701	2138MBL705	Angle Wrench		1
702	2138MBL706	Angle Wrench		1
806	280630RD	Lead Wire (1ph)		1
807	280630RH	Lead Wire (1ph)		1
814	2813DH5502	Wire Connector		1
815	2668BZDA04	Pan Head Screw	M3x20	2
822	26682Z52	Pad Head Screw	M5x25mm	4
834	10483401	Insulating Barrier		1
848	2658MZDU36	Drive Screw		2
849	10884901	Scale		1
899	2641BBDA23	Pan Head Screw	M5x8mm	2
912	2705FBD105	Nut Chuck	M5	1
920	10892001	Tension Plate		1
922	2801ABRF04	Strain Belief		2
300	2130555540A2	Vise		1
301	2801ANHJ37	Strain Relief		1
302	280655512D	LEAD WIRE ASS'Y		1
303	10042TKG	Warning Label		1
304	280655513D	LEAD WIRE ASS'Y		1
305	10042TL2	Caution Label		1
306	28042R8K	Fuse		1
307	107825Q0	Warning Label		1
308	10042R76	Dust Guard		1
309	10817301	Warning Label		1
310	10042TKZ	Caution Label		1
311	10062Z3R	Dust Guard		1
312	10042R77	Dust Guard		1
313	10042TKF	Caution Label		1
314	10042TKP	Caution Label		1
315	10042TKU	Caution Label		1

# JDP-15

10000370M....230/50/1

10000370T....400/50/3

	colour of strands	Litzenfarben	couleur des cordons
BK	black	schwarz	noir
WH	white	weiß	blanc
BU	blue	blau	bleu
YE	yellow	gelb	jaune
RD	red	rot	rouge
BN	brown	braun	brun
GY	grey	grau	gris
GNYE	green-yellow	grün-gelb	vert-jaune
OG	orange	orange	orange
VT	violet	violett	violet

	meaning of symbol	Bedeutung der Zeichen	interprétation
M	motor	Motor	moteur
S	switch	Schalter	interrupteur
C	condenser	Kondensator	condensateur
E	electronic unit	Elektronik Einheit	unité électronique
F	fuse	Sicherung	fusible
RS	reversing switch	Drehrichtungsschalter	commu. droite/gauche
CS	centrifugal switch	Fliehkraftschalter	déclencheur centrifuge
OL	overload cut-off	Überlastschutzschalter	déclencheur surcharge

## 230/50/1

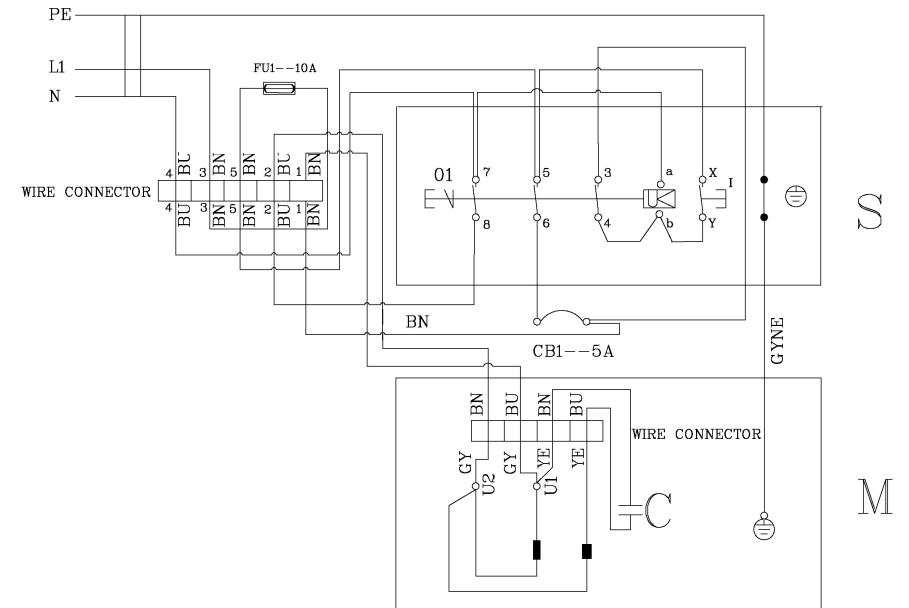

## 400/50/3

