

# **JET**

**JWL-1236**

**WOODWORKING LATHE**

**708352M**

**230/50/1**

## **PARTS LIST**

**Walter Meier (Fertigung) AG**

Bahnstrasse 24

8603 Schwerzenbach

Switzerland

Phone +41 44 806 47 48

Fax +41 44 806 47 58

[jetinfo.eu@waltermeier.com](mailto:jetinfo.eu@waltermeier.com)

[www.jettools.com](http://www.jettools.com)



P-708352M 2010/03/26

Lathe Assembly

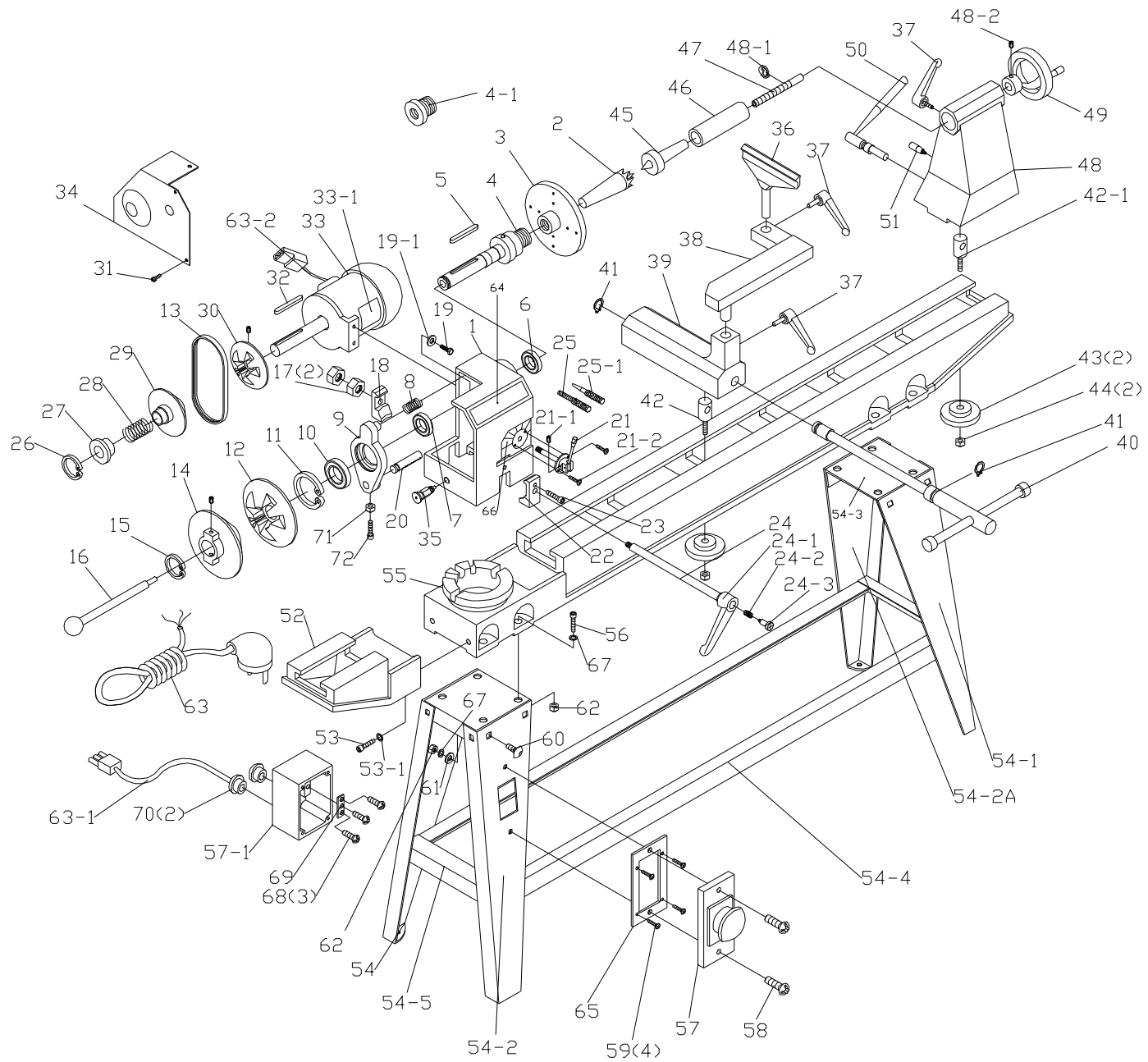

## Parts List for the JWL-1236 Wood Lathe

Index No.	Part No.	Description	Size	Qty.
1	JWL1236-01	Headstock		1
2	JWL1236-02	Spur Center	MT2	1
3	JWL1236-03	Face Plate	6"	1
4	JWL1236-04E	Spindle	1"×8T.P.I.	1
	JWL1236-04-1E	Spindle Adapter	M33×3.5	1
5	JWL1236-05	Key	4×4×85	1
6	BB-6005ZZ	Ball Bearing		1
7	BB-6005ZZ	Ball Bearing		1
8	JWL1236-08	Spring		1
9	JWL1236-09	Shifting Lever Bracket		1
10	BB-6006Z	Ball Bearing		1
11	JWL1236-11	C-Clip	S-25	1
12	JWL1236-12	Spindle Pulley(right)		1
13	VB-M22	V-Belt		1
14	JWL1236-14	Spindle Pulley(left)		1
15	JWL1236-15	C-Clip	S-24	1
16	JWL1236-16E	Drift Rod		1
17	JWL1236-17	Lock Nut	1/2	2
18	JWL1236-18	Clamp(Left)		1
19	TS-0011031	Hex Head Bolt	5/16×3/4	2
19-1	TS-0720081	Lock Washer	5/16	2
20	JWL1236-20	Rack		1
21	JWL1236-21	Speed Selector Assembly		1
21-1	JWL1236-21-1	Pan Head Screw		2
21-2	JWL1236-21-2	Set Screw	5/16	1
22	JWL1236-22	Clamp(right)		1
23	JWL1236-23	Hex Head Screw		1
24	JWL1236-24	Headstock Lock		1
24-1	JWL1236-24-1	Headstock Lock Handle		1
24-2	JWL1236-24-2	Spring		1
24-3	JWL1236-24-3	Screw		1
25	JWL1236-25	Index Tool		1
25	JWL1236-25-1	Index Tool		1
26	JWL1236-26	C-Clip	S-16	1
27	JWL1236-27	Sleeve		1
28	JWL1236-28	Spring		1
29	JWL1236-29	Motor Pulley (right)		1
30	JWL1236-30	Motor Pulley (left)		1
31	JWL1236-31	Pan Head Screw	3/16×3/8	4
32	JWL1236-32	Key	4×4×85	1
33	JWL1236-33E	Motor W/Motor Cord		1
	JWL-1236-SCE	Start Capacitor (not shown-200MFD, 250 VAC)		1
	JWL-1236-RCE	Running Capacitor (not shown-30•F/ 250VAC)		1
33-1	JWL1236-33-E	Nameplate		1
34	JWL1236-34	Motor Cover		1
35	JWL1236-35	Index Plunger		1
36	JWL1236-36A	Tool Rest		1

Index No.	Part No.	Description	Size	Qty.
37	JWL1236-37	Handle		3
38	JWL1236-38A	Tool Rest Extension	1"	1
39	JWL1236-39A	Tool Rest Body	1"	1
40	JWL1236-40	Eccentric Rod		1
41	JWL1236-26	C-Clip	S-16	2
42	JWL1236-42	Bolt		1
42-1	JWL1236-42-1	Bolt		1
43	JWL1236-43	Clamp		2
44	TS-0561081	Nut	3/4	2
45	JWL1236-45	Live Center		1
46	JWL1236-46	Tail Spindle		1
47	JWL1236-47	Tailstock Screw		1
48	JWL1236-48	Tailstock		1
48-1	JWL1236-48-1	C-Ring	S-16	1
48-2	JWL1236-48-2	Set Screw	1/4	1
49	JWL1236-49	Hand-Wheel		1
50	JWL1236-50	Tailstock Lock Handle		1
51	JWL1236-51	Handle Stop		1
52	JWL1236-52	Bed Extension		1
53	TS-0209051	Hex Socket Cap Screw	3/8x1	2
53-1	TS-0720091	Lock Washer	3/8	2
54	JWL1236-54	Stand Leg (left rear)		1
54-1	JWL1236-54-1	Stand Leg (right front)		1
54-2	JWL1236-54-2	Stand Leg (left front- switch)		1
54-2-A	JWL1236-54-2	Stand Leg (right rear)		1
54-3	JWL1236-54-3	Stand Top		2
54-4	JWL1236-54-4	Long Brace		2
54-5	JWL1236-54-5	Short Brace		2
55	JWL1236-55	Bed		1
56	TS-0208061	Hex Socket Cap Screw	5/16x1	8
57	JWL1236-57E	Magnetic Switch (VDE)		1
57	JWL1236-57-1E	Switch Box (VDE)		1
58	JWL1236-58	Screw	M4x24	2
59	JWL1236-59	Pan Head Screw	3/16	4
60	TS-0152011	Carriage Bolt	5/16x1	24
61	TS-0680031	Washer	5/16	24
62	TS-0561021	Nut	5/16	24
63	JWL1236-63E	Power Cord (VDE)		1
63-1	JWL1236-63-1E	Power Cord (VDE)		1
63-2	JWL1236-63-2E	Motor Cord (VDE)		1
64	JWL1236-4	JET Label		1
65	JWL1236-65E	Switch Plate		1
66	JWL1236-66	Speed Label		1
67	TS-0720081	Lock Washer	5/16	32
68	JWL1236-68E	Round Head Screw		3
69	JWL1236-69E	Plate		1
70	JWL1236-70E	Strain Relief Bushing (VDE)		2
71	JWL1236-71E	Hex Nut	1/4	1
72	JWL1236-72E	Hex Socket Cap Bolt	1/4x20	1

**JWL-1236**  
**708352M**

**230/50/1**

	colour of strands	Litzenfarben	couleur des cordons
BK	black	schwarz	noir
WH	white	weiß	blanc
BU	blue	blau	bleu
YE	yellow	gelb	jaune
RD	red	rot	rouge
BN	brown	braun	brun
GY	grey	grau	gris
GNYE	green-yellow	grün-gelb	vert-jaune
OG	orange	orange	orange
VT	violet	violett	violet

	meaning of symbol	Bedeutung der Zeichen	interprétation
M	motor	Motor	moteur
S	switch	Schalter	interrupteur
C	condenser	Kondensator	condensateur
E	electronic unit	Elektronik Einheit	unité électronique
F	fuse	Sicherung	fusible
RS	reversing switch	Drehrichtungsschalter	commu. droite/gauche
CS	centrifugal switch	Fliehkraftschalter	déclencheur centrifuge
OL	overload cut-off	Überlastschuttschalter	déclencheur surcharge
LS	limit switch	Positionsendschalter	micro

